

STAINLESS STEEL SWAGE TERMINALS

Swage Studs RH & LH with Imperial Threads

Benefits

Free from structural welds which may reduce the strength and integrity of the product.

All Swage Studs are manufactured from solid bar.

Available in Open or Closed body Style.

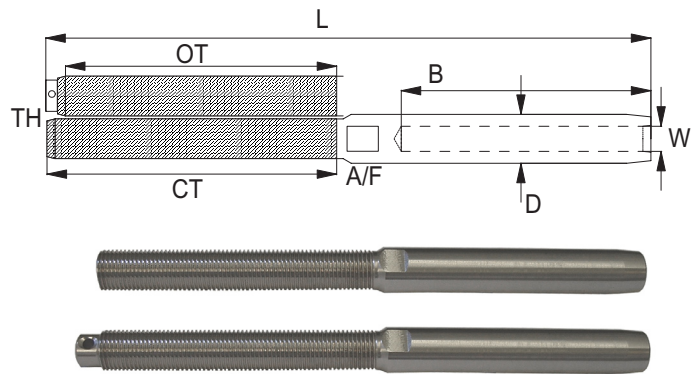

Swage Studs with Imperial Threads

Product Code	W	TH	D	B	L	CT	OT	A/F	Weight
S#1/4x3	3mm	1/4" unf	6.3mm	39mm	97mm	47mm	42mm	5mm	24g
S#1/4x4	4mm	1/4" unf	7.5mm	45mm	104mm	47mm	42mm	5mm	30g
S#5/16x4	4mm	5/16" unf	7.5mm	45mm	113mm	54mm	49mm	6mm	36g
S#5/16x5	5mm	5/16" unf	9.1mm	52mm	123mm	54mm	49mm	6mm	51g
S#3/8x5	5mm	3/8" unf	9.1mm	52mm	135mm	68mm	63mm	8mm	60g
S#3/8"x6	6mm	3/8" unf	12.5mm	64mm	149mm	68mm	63mm	8mm	85g
S#7/16x6	6mm	7/16" unf	12.5mm	64mm	154mm	75mm	68mm	11mm	108g
S#7/16x7	7mm	7/16" unf	14.3mm	70mm	161mm	75mm	68mm	11mm	130g
S#1/2x7	7mm	1/2" unf	14.3mm	70mm	177mm	90mm	83mm	12mm	162g
S#1/2x8	8mm	1/2" unf	16.0mm	80mm	190mm	90mm	83mm	14mm	196g
S#5/8x8	8mm	5/8" unf	16.0mm	80mm	201mm	100mm	93mm	14mm	260g
S#5/8x10	10mm	5/8" unf	18.0mm	100mm	223mm	100mm	93mm	16mm	306g
S#3/4x12	12mm	3/4" unf	21.4mm	132mm	277mm	120mm	111mm	19mm	550g
S#7/8x14	14mm	7/8" unf	25.0mm	156mm	325mm	140mm	130mm	22mm	874g
S#1x16	16mm	1" unf	28.2mm	176mm	369mm	160mm	150mm	25mm	1275g
S#11/8x19	19mm	1 1/8" unf	34.5mm	210mm	425mm	180mm	168mm	28mm	2050g
S#11/4x22	22mm	1 1/4" unf	40.3mm	242mm	482mm	200mm	188mm	32mm	3200g
S#13/8x26	26mm	1 3/8" unf	45.9mm	290mm	557mm	220mm	208mm	36mm	4000g

Replace # with C for Closed Body Style (CT) or O for Open Body Style (OT)

All Hi-MOD products are produced to a high degree of quality control, using modern lean manufacturing processes, resulting in a reliable and consistent product